

WARNING: SHOCK HAZARD

Turn OFF the power to the branch circuit for the switch and lighting fixture at the service panel. All wiring connections must be made with the POWER OFF to avoid personal injury and/or damage to the dimmer.

This device is intended for installation per the National and Canadian Electrical Code as well as the United States and Canadian local regulations.

If you are unsure or uncomfortable about performing the installation, consult a qualified electrician.

ATTENTION : RISQUE DE CHOC ÉLECTRIQUE

ÉTEIGNEZ l'alimentation du circuit de dérivation pour l'interrupteur et l'appareil d'éclairage au panneau de service. Toutes les connexions électriques doivent être effectuées HORS TENSION afin d'éviter tout risque de blessure personnelle et/ou de dommage au variateur. Cet appareil est destiné à être installé conformément au Code électrique national et aux réglementations locales aux États-Unis, ainsi qu'au Code électrique canadien et aux réglementations locales au Canada.

Si vous avez des doutes ou si vous ne vous sentez pas à l'aise pour effectuer l'installation, consultez un électricien qualifié.

IMPORTANT: This dimmer is rated for and intended to only be used with copper wire.

0-10V Smart Dimmer Wiring/Installation Instructions

1. Shut off power to the circuit at the circuit breaker or fuse box.

IMPORTANT: Verify power is OFF to the switch box before continuing.

2. Remove wall plate.
3. Remove the switch mounting screws.
4. Carefully remove the switch from the switch box.
Note: DO NOT disconnect the wires.
5. There are up to seven screw terminals on the dimmer, these are marked:
 - GROUND
 - LINE - black (connected to power)
 - LOAD - black or red (connected to lighting/load)
 - TRAVELER - black or red (only in 3-way installations)
 - NEUTRAL - white
 - +/- Output terminals
6. Match these screw terminals to the wires connected to the existing switch.

7. Disconnect the wires from the existing switch.
8. Label wires according to the previous terminal connection.

Multi-Switch Wiring

For 3-way installations, refer to the [Install Guide - QoraLux Companion Switch](#).

Wire Gauge Requirements

Use 12 AWG or 14 AWG wires suitable for at least 75 °C for supplying line (hot), load, neutral, ground, and traveler connections. Use 16–26 AWG wire for 0–10 V connections.

Air Gap

The air gap switch on the bottom must be pulled out when replacing light bulbs, this disconnects power to the load. When installation is finished, the air gap switch needs to be pushed back in for the device to function properly.

Wire Strip Length

For attachment using the enclosure's holes, strip insulation 5/8 in (16 mm). UL specifies the tightening torque for the screws is 14 Kgf/cm² (12 lbf/in²). Refer to the diagram and follow the steps below.

1. Connect the green or bare copper ground wire to the GROUND terminal.
2. Connect the black wire from the light to the LOAD terminal.
3. Connect the black wire from the electrical service panel (hot) to the LINE terminal.
4. Connect the white wire to the NEUTRAL terminal (use a jumper wire if needed).

Note: The traveler terminal is only used for 3- or 4-way wiring and should not be connected if the dimmer is being installed in a 2-way system (one dimmer and one load).

5. Insert dimmer into the switch box being careful not to pinch or crush wires.

6. The switch must be independently mounted (vertical position only).
7. Secure the switch to the box using the supplied screws.
8. Mount the wall plate.
9. Reapply power to the circuit at fuse box or circuit breaker and test the system.

Basic Operation

The connected light can be turned ON/OFF in two ways.

- Manually from the front panel of the dimmer
- Remotely via the SAVI Server

Manual Control

The front panel rocker switch allows the user to turn ON/OFF or Dim UP/DN the connected fixture by completing the following steps:

1. Press the top of the rocker to turn the light ON or press the bottom to turn it OFF.
2. Connected to dimmer and press/hold the top of the rocker to dim UP, or press/hold the bottom to dim DOWN.

3-Way Circuit (Companion switch)

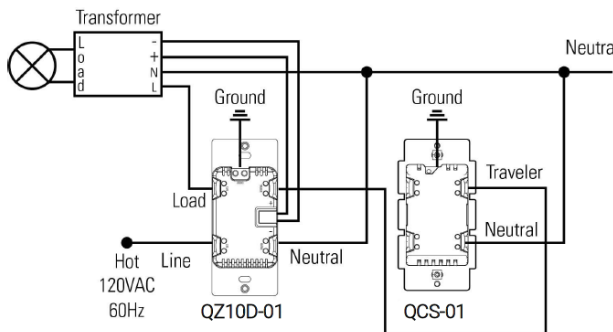

Off the shelf 3-Way Circuit

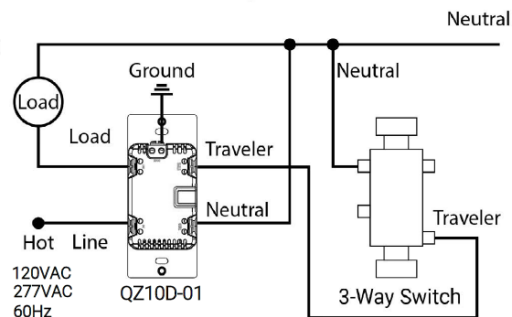

Note: For 3-way configurations, ensure the smart dimmer is installed in the junction box where Line (Hot) enters the electrical circuit. Insert wires into holes, do not wrap wires around screws. Do not remove screws. The Qoralux Smart Dimmer is designed to operate in either 120 VAC or 277 VAC circuits. For 277 VAC 3-way circuits, use standard "off-the-shelf" 277 VAC compatible 3-way switch.

Refer to the **Documentation** section on [SAVI's dealer portal](#) for user guides, datasheets, and more.

LEGAL

Input: 120/277 VAC 60 Hz
Resistive: 8 A@120 V/5 A@277 V
Electronic Ballast: 960 VA@120 V/1385 VA@277 V
General Use (Inductive): 960 VA@120 V/1385 VA@277 V
Operating ambient temperature 0–40 °C
Not suitable for disconnecting means.

FCC

Supplier's Declaration of Conformity
47 CFR 2.1077 Compliance Information
Model: QZ10D-01
Responsible Party – US Contact Information
2520 Marsh Lane, Carrollton, TX 75006-2401
(214) 785-6510

This device complies with part 15 of the FCC rules. Operation is subject to the following two conditions: (1) this device may not cause harmful interference, and (2) this device must accept any interference received, including interference that may cause undesired operation.

Note: The manufacturer is not responsible for any radio or TV interference caused by unauthorized modifications or changes to this equipment. Such modifications or changes could void the user's authority to operate the equipment. Please visit savicontrols.com to find the full FCC/IC statements.

This equipment complies with FCC radiation exposure limits set forth for an uncontrolled environment and should be installed and operated with a minimum distance of 20 cm between the radiator and any part of your body.

IC

This device complies with Part 15 of the FCC Rules and with RSS of Industry Canada. Operation is subject to the following two conditions:

- This device may not cause harmful interference.
- This device must accept any interference received, including interference that may cause undesired operation.

This equipment complies with ISED RSS-102 radiation exposure limits set forth for an uncontrolled environment and should be installed and operated with a minimum distance of 20 cm between the radiator and any part of your body.

Le présent appareil est conforme aux CNR d'Industrie Canada applicables aux appareils radio exempts de licence. L'exploitation est autorisée aux deux conditions suivantes:

1. L'appareil ne doit pas produire de brouillage, et
2. L'utilisateur de l'appareil doit accepter tout brouillage radioélectrique subi, même si le brouillage est susceptible d'en compromettre le fonctionnement.
3. Pour se conformer aux exigences de conformité CNR 102 RF exposition, une distance de séparation d'au moins 20 cm doit être maintenue entre l'antenne de cet appareil et toutes les personnes.

This Class B digital apparatus complies with Canadian ICES-003.

Cet appareil numérique de la classe B est conforme à la norme NMB-003 du Canada